



- Compliance with International Codes
- Compliance with State Codes

ICC-ES Evaluation Report ESR-2504

Reissued May 2023

This report is subject to renewal May 2024.

DIVISION: 06 00 00—WOOD, PLASTICS AND COMPOSITES
Section: 06 17 00—Shop-Fabricated Structural Wood

REPORT HOLDER:

SWEET'S JOISTS, INC.

ADDITIONAL LISTEE:

WEB JOIST NORTHWEST CORP.

EVALUATION SUBJECT:

WEB JOIST™ TRUSSES

1.0 EVALUATION SCOPE

1.1 Compliance with the following codes:

- 2018, 2015, and 2012 *International Building Code*® (IBC)
- 2018, 2015, and 2012 *International Residential Code*® (IRC)

Properties evaluated:

- Structural
- Fire resistance

1.2 Evaluation to the following green code(s) and/or standards:

- 2022 California Green Building Standards Code (CALGreen), Title 24, Part 11
- 2020, 2015, 2012 and 2008 ICC 700 *National Green Building Standard*™ (ICC 700-2020, ICC 700-2015, ICC 700-2012 and ICC 700-2008)

Attributes verified:

See Section 3.1

2.0 USES

The Web Joist trusses described in this report are used as structural framing members in floor and roof assemblies.

3.0 DESCRIPTION

3.1 General:

The Web Joist trusses are Warren-style, pin-connected trusses that have either parallel, tapered, or pitched-chord members. The trusses have wood chords, steel webs, and

steel pin web-to-chord connectors. There are two versions of the trusses: Version 1 Truss and Version 2 Truss. See Table 1 and Figure 1 for a description of truss components.

The attributes of the wood trusses have been verified as conforming to the provisions of (i) CALGreen Section A4.404.3 for efficient framing techniques; (ii) ICC 700-2020 Sections 608.1(2), 11.608.1(2) and 13.104.3.1(4); (iii) ICC 700-2015 Sections 608.1(2), 11.608.1(2) and 12.1(A).608.1(b) for resource-efficient materials; (iv) ICC 700-2012 Sections 608.1(2), 11.608.1(2) and 12.1(A).608.1; and ICC 700-2008 Section 607.1(2) for resource-efficient materials. Note that decisions on compliance for those areas rest with the user of this report. The user is advised of the project-specific provisions that may be contingent upon meeting specific conditions, and the verification of those conditions is outside the scope of this report. These codes or standards often provide supplemental information as guidance.

3.1.1 Version 1 Truss: Eight Version 1 trusses are recognized: WJSS, WJ21, WJ24, WJ27, WJ28 WJ21W, WJ24W and WJ28W. The chords are 1½-by-3½-inch (38 by 89 mm) or 1½-by-5½-inch (38 by 140 mm) solid-sawn lumber. The webs are either steel tubing or steel angles.

3.1.2 Version 2 Truss: One Version 2 truss is recognized: WJ-L6. The chords are 2½-by-3½-inch (63.5 by 89 mm) LAM-CHORD. The webs are either steel tubing or steel angles.

3.2 Materials:

3.2.1 Chords: Chords consist of either solid-sawn lumber or LAM-CHORD. The chords have glued finger joints, which are manufactured and tested daily in accordance with the manufacturer's quality control manual, to form continuous chord members. Chords have routs in the wide face to accept web members, and the routs comply with tolerance limits specified in the manufacturer's quality control manual.

3.2.1.1 Solid-sawn Lumber: Lumber grade is either machine-stress-rated (MSR) or Select Structural. The MSR lumber species is either Douglas fir–larch, hem-fir, spruce-pine-fir, Englemann spruce–lodgepole pine, or lodgepole pine. Lumber grades comply with the grading rules specified in Tables 4A and 4C of the American Wood Council (AWC) National Design Specification (NDS) Supplement and the manufacturer's quality control manual. The wood species of the Select Structural lumber is Douglas fir–larch.

3.2.1.2 LAM-CHORD: LAM-CHORD is a manufactured laminated lumber complying with ANSI A 190.1, and each piece of ripped LAM-CHORD material conforms with visual grading rules specified in the manufacturer's quality control manual. Lumber species is either Douglas fir or hem-fir.

3.2.2 Webs: The steel tubing truss webs are formed from welded, galvanized, round steel tubing conforming to ASTM A500, Grade C, with minimum yield and tensile strengths as specified in the manufacturer's quality control manual. The tubing is galvanized with a minimum G60 galvanization coating weight in accordance with ASTM A787. The steel angle truss webs are cold-formed from galvanized steel coil conforming to ASTM A653 SS Grade 33, with a minimum G60 galvanization coating weight and minimum yield and tensile strengths as specified in the manufacturer's quality control manual.

3.2.3 Pin Connectors: The pins are 3¹/₂- or 5¹/₂-inch-long (89 mm or 140 mm), solid steel pins, having either ³/₈-, ¹/₂-, ⁵/₈-, or ³/₄-inch (9.5, 12.7, 15.9 or 19.1 mm) diameters. The ³/₈- and ¹/₂-inch-diameter (9.5 and 12.7 mm) pins are ASTM A449 steel with heat treatment; the ⁵/₈- and ³/₄-inch-diameter (15.9 and 19.1 mm) pins are ASTM A307 steel.

3.2.4 Bearing Clips: Steel bearing clips are No. 13 gage [0.089-inch-thick (2.3 mm)], cold-formed ASTM A1011, SS designation, Grade 40; or ASTM A653, SS designation, Grade 40.

4.0 DESIGN AND INSTALLATION

4.1 Installation:

Installation of the Web Joist trusses described in this report must comply with the applicable code requirements, this report and the manufacturer's published installation instructions. The manufacturer's published installation instructions must be available at the jobsite at all times during installation.

4.2 Design:

4.2.1 General: The trusses must be designed using accepted truss design principles and this report.

4.2.2 Chord Members: Table 2 provides section properties and Table 3 provides allowable unit stresses for the truss chord members.

4.2.3 Web Members: Table 5 provides allowable tension and compression loads for truss web members.

4.2.4 Pin Connectors: Table 4 provides allowable loads for pin connectors bearing on wood. The allowable load for the resultant of parallel and perpendicular pin loading on the chord member must be determined using Equation 12.3-11 in Section 12.3.4 of the 2018 and 2015 NDS (Equation 11.3-11 in Section 11.3.4 of the 2012 NDS).

4.2.5 Bearing Assembly: Table 6 provides allowable reactions at supports with bearing clips. See Figure 2.

4.2.6 Duration of Load: Allowable unit stress of chord members may be adjusted for duration of load in accordance with Section 2.3.2 of the NDS. Allowable parallel-to-grain wood bearing loads on pins (Table 4) may be adjusted for duration of load in accordance with Section 2.3.2 of the NDS, up to a maximum load duration factor, C_D , of 1.60. No other design values for the web joist trusses are to be increased for duration of load.

4.2.7 Repetitive Member Use: When trusses comply with code-defined repetitive member use according to Section 4.3.9 of the NDS, the allowable parallel-to-grain tension and compression stresses noted in Table 3 may be increased 7 percent for MSR and LAM-CHORD lumber chords.

4.2.8 Deflection: Deflection of a uniformly loaded truss is approximated with the classic, uniformly loaded, simple-span beam-deflection formula. The moment of inertia of the truss consists of only the top and bottom chord members, without considering reduced areas from pins or routs.

4.3 One-hour Fire-resistance-rated Roof and Floor-ceiling Assemblies:

Web Joist trusses used in one-hour fire-resistance-rated roof and floor-ceiling assemblies must be installed in accordance with Section 4.2.2.4 of [ESR-1338](#), or 2018, 2015 and 2012 IBC Table 721.1(3) Item No. 21-1.1.

5.0 CONDITIONS OF USE

The Web Joist trusses described in this report comply with, or are suitable alternatives to what is specified in, those codes listed in Section 1.0 of this report, subject to the following conditions:

5.1 Installation complies with this report, the manufacturer's published installation instructions and the applicable code. In the event of conflicts between the manufacturer's published installation instructions and this report, this report governs.

5.2 Structural design information for the use of the trusses must be indicated on the construction documents submitted with the permit application. The construction documents and the design configurations must be consistent with this report, and must be prepared by a registered design professional where required by the statutes of the jurisdiction in which the project is to be constructed.

5.3 Cutting of the chords of the trusses is not permitted.

5.4 Evaluation of the trusses is limited to interior dry-use conditions. Dry conditions of use are those conditions of use represented by moisture content that is less than 19 percent in the sawn lumber truss chords.

5.5 The trusses are manufactured by Web Joist Northwest Corp. in Chehalis, Washington, under a quality-control program with inspections by ICC-ES and PFS Corporation (AA-652).

6.0 EVIDENCE SUBMITTED

Data in accordance with the ICC-ES Acceptance Criteria for Pin-connected Open-web Trusses with Wood Chords and Tubular or Angular Steel Webs (AC306), dated April 2019.

7.0 IDENTIFICATION

7.1 Each Web Joist truss bears a stamped identification label with the product name (Web Joist Truss), manufacturer's name (Web Joist Northwest Corp.), manufacturer's city and state, the evaluation report number (ESR-2504), and the name of the inspection agency (PFS Corporation). In addition, the chords of the trusses are labeled with the applicable lumber grade stamp.

7.2 The report holder's contact information is the following:

SWEET'S JOISTS, INC.
118 BOROVEC ROAD
CHEHALIS, WASHINGTON 98532-8714
(360) 748-1173
www.webjoist.com
Bruce@webjoist.com

7.3 The Additional Listee's contact information is the following:

WEB JOIST NORTHWEST CORP.
118 BOROVEC ROAD
CHEHALIS, WASHINGTON 98532
(360) 748-1173

TABLE 1—COMPONENTS OF WEB JOIST VERSION 1 AND VERSION 2 TRUSSES

Component		Version 1 Truss								Version 2 Truss WJ-L6
		WJSS	WJ21	WJ24	WJ27	WJ28	WJ21W	WJ24W	WJ28W	
Chords	Sel. Str. DF 1.5"x3.5"	YES	---	---	---	---	---	---	---	---
	MSR 2100f-1.8E 1.5"x3.5"	YES	YES	YES	---	---	---	---	---	---
	MSR 2400f-2.0E 1.5"x3.5"	---	---	YES	YES	YES	---	---	---	---
	MSR 2700f-2.2E 1.5"x3.5"	---	---	---	YES	---	---	---	---	---
	MSR 2850f-2.3E 1.5"x3.5"	---	---	---	---	YES	---	---	---	---
	MSR 2100f-1.8E 1.5"x5.5"	---	---	---	---	---	YES	YES	---	---
	MSR 2400f-2.0E 1.5"x5.5"	---	---	---	---	---	---	YES	YES	---
	MSR 2850f-2.3E 1.5"x5.5"	---	---	---	---	---	---	---	YES	---
LAM-CHORD 2.5"x3.5"	---	---	---	---	---	---	---	---	YES	
Pins	3/8" Diameter x 3 1/2" Long	YES	YES	YES	YES	YES	---	---	---	---
	3/8" Diameter x 5 1/2" Long	---	---	---	---	---	YES	YES	YES	---
	1/2" Diameter x 3 1/2" Long	---	---	---	---	---	---	---	---	YES
	5/8" Diameter x 3 1/2" Long	YES	YES	YES	YES	YES	---	---	---	---
	5/8" Diameter x 5 1/2" Long	---	---	---	---	---	YES	YES	YES	---
	3/4" Diameter x 3 1/2" Long	---	---	---	---	---	---	---	---	YES
Webs (Tubing)	1.000" O.D. - 19 Ga.	YES	YES	YES	YES	YES	YES	YES	YES	YES
	1.000" O.D. - 18 Ga.	YES	YES	YES	YES	YES	YES	YES	YES	YES
	1.000" O.D. - 16 Ga.	YES	YES	YES	YES	YES	YES	YES	YES	---
	1.000" O.D. - 14 Ga.	YES	YES	YES	YES	YES	YES	YES	YES	---
	1.125" O.D. - 16 Ga.	YES	YES	YES	YES	YES	YES	YES	YES	---
	1.125" O.D. - 13 Ga.	YES	YES	YES	YES	YES	YES	YES	YES	---
	1.250" O.D. - 19 Ga.	---	---	---	---	---	---	---	---	YES
	1.250" O.D. - 18 Ga.	---	---	---	---	---	---	---	---	YES
	1.250" O.D. - 16 Ga.	---	---	---	---	---	---	---	---	YES
	1.250" O.D. - 14 Ga.	---	---	---	---	---	---	---	---	YES
	1.500" O.D. - 16 Ga.	---	---	---	---	---	---	---	---	YES
	1.500" O.D. - 14 Ga.	---	---	---	---	---	---	---	---	YES
1.500" O.D. - 13 Ga.	---	---	---	---	---	---	---	---	YES	
Webs (2-Angles)	0.75" x 0.75" x 0.10"	YES	YES	YES	YES	YES	YES	YES	YES	---
	1.125" x 1.125" x 0.10"	---	---	---	---	---	---	---	---	YES
Bearing Clips	Angle Clip (A1)	YES	YES	YES	YES	YES	YES	YES	YES	---
	Angle Clip (A2)	---	---	---	---	---	---	---	---	YES

For SI: 1 in. = 25.4 mm.



WEB JOIST™ Wood & steel open web trusses

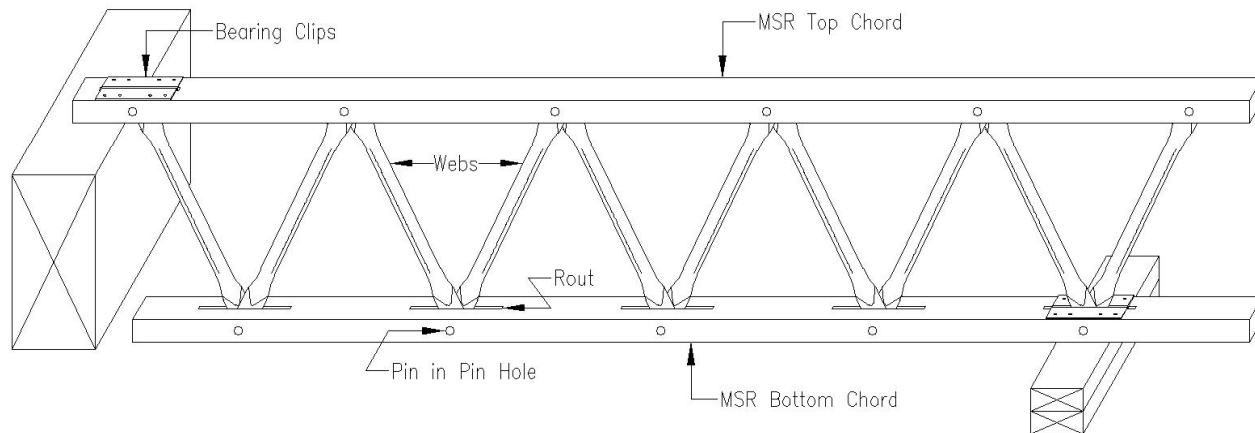

FIGURE 1—TRUSS COMPONENTS

TABLE 2—CHORD SECTION PROPERTIES¹

Version	Chord Size (inches)	Pin Dia. (inches)	Rout Width (inches)	Areas (inches ²)		Section Modulus (inches ³)
				Tension	Compression	
Ver. 1 2x4	Depth = 1.5	no pin	no rout	5.25	5.25	1.31
	by	0.375	0.219	3.69	4.92	1.21
	Width = 3.5	0.625	0.375	2.73	4.69	1.09
Ver. 1 2x6	Depth = 1.5	no pin	no rout	8.25	8.25	2.06
	by	0.375	0.219	5.94	7.92	1.95
	Width = 5.5	0.625	0.375	4.48	7.69	1.78
Ver. 2 3x4	Depth = 2.5	no pin	no rout	8.75	8.75	3.65
	by	0.500	0.313	6.38	7.97	3.29
	Width = 3.5	0.750	0.438	5.36	7.66	3.10

For SI: 1 in = 25.4 mm, 1 in² = 645.16 mm², 1 in³ = 16387 mm³.

¹The section modulus is about the neutral axis of the chord member and is used for combined stress analysis of the chord member when chord supports uniform load between panel points.

TABLE 3—ALLOWABLE CHORD UNIT STRESS IN POUNDS PER SQUARE INCH¹

Version	Lumber Grade ²	Tension Parallel to Grain (F _t)	Compression Parallel to Grain (F _c)	Extreme Fiber In Bending (F _b)	Modulus of Elasticity (E x 10 ⁶)
Ver. 1	Sel. Str. DF ³	1,500 ⁴	1,955 ⁴	2,175 ^{4,5}	1.90
	MSR 2100f-1.8E ³	1,575	1,875	2,100 ⁵	1.80
	MSR 2400f-2.0E	1,925	1,975	2,400 ⁵	2.00
	MSR 2700f-2.2E	2,150	2,100	2,700 ⁵	2.20
	MSR 2850f-2.3E	2,300	2,150	2,850 ⁵	2.30
Ver. 2	LAM-CHORD	2,050	1,975	2,400 ⁶	2.10

For SI: 1 psi = 6.895 kPa.

¹Other allowable working stresses for solid sawn chords are provided in Tables 4A and 4C of the NDS.

²Lumber grades are indicated by grade stamps on the chord members.

³The Select Structural Douglas fir-Larch and MSR 2100f-1.8E chord grades are available only for 2x4 chords.

⁴The F_t, F_c and F_b values given for 2x4 Select Structural Douglas fir-Larch chord members have already been adjusted by the Size Factor, C_F.

⁵F_b may be increased 10 percent for flatwise use.

⁶F_b may be increased 10 percent for laminating factor.

TABLE 4—ALLOWABLE WOOD BEARING LOADS ON PINS IN POUNDS^{1,2,3,4}

Angle of Load to Grain of Chord	Version 1 Truss ⁵		Version 2 Truss ⁶	
	³ / ₈ " Pin	⁵ / ₈ " Pin	¹ / ₂ " Pin	³ / ₄ " Pin
Parallel	1,320	2,540	2,545	3,665
Perpendicular	800	900	1,445	1,730

For SI: 1 in = 25.4 mm, 1 lbf = 4.448 N.

¹Parallel: Adjustments for duration of load per Section 2.3.2 of NDS are applicable, up to a maximum load duration factor, C_D, of 1.60.

²Perpendicular: Adjustments for duration of load are not applicable.

³The pins are subjected to loads both parallel and perpendicular to the length of the chord. The allowable load for the resultant of these two forces acting on the pin may be determined from the Hankinson formula based on the controls in this section.

⁴The minimum end distance between the pin and end of the chord shall be 1.75 inches for Version 1 truss and 2.25 inches for Version 2 truss for a pin force acting away from the end of the chord and 6 inches for a pin force acting toward the end of the chord.

⁵Values are for Douglas fir-larch (DF-L), hem-fir (HF), southern pine (SP), spruce-pine-fir (SPF), Englemann spruce/lodgepole pine (ES/LP), or lodgepole pine (LP).

⁶Values are for hem-fir and may be increased 10 percent for Douglas fir-larch.

TABLE 5—ALLOWABLE WEB MEMBER LOADS IN POUNDS^{1,2}

Diameter(inches) - Gauge No. (Ga. color or No.)	Design Wall Thickness (inches)	Load Condition	Version 1 Truss WJSS, WJ21, WJ24, WJ27, WJ28, WJ21W, WJ24W and WJ28W		Version 2 Truss WJ-L6	
			³ / ₈ " Pin	⁵ / ₈ " Pin	¹ / ₂ " Pin	³ / ₄ " Pin
1.000-19 (Blue or None)	0.040	Tension Compression	1,437 1,437@≤36.5"	1,348 1,791@≤31.6"	1,917 1,831@≤30.2"	— —
1.000-18 (Black or 8)	0.047	Tension Compression	1,721 1,721@≤35.6"	1,713 2,457@≤25.6"	2,295 2,295@≤27.8"	— —
1.000-16 (Red or 6)	0.063	Tension Compression	— —	2,466 2,748@≤30.1"	— —	— —
1.000-14 (Green or 4)	0.082	Tension Compression	— —	3,226 5,185@≤15.7"	— —	— —
1.125-16 (Red or 6)	0.063	Tension Compression	— —	2,350 3,995@≤25.2"	— —	— —
1.125-13 (Yellow or 3)	0.094	Tension Compression	— —	3,771 6,452@≤19.5"	— —	— —
2 Angles 0.75"x0.75"	0.100	Tension Compression	— —	3,512 1,220@≤20.0"	— —	— —
1.250-19 (Blue or None)	0.040	Tension Compression	— —	— —	1,917 1,917@≤44.2"	2,129 2,487@≤35.2"
1.250-18 (Black or 8)	0.047	Tension Compression	— —	— —	2,295 2,295@≤43.2"	2,431 2,478@≤40.7"
1.250-16 (Red or 6)	0.063	Tension Compression	— —	— —	3,206 3,206@≤40.9"	3,471 4,719@≤25.4"
1.250-14 (Green or 4)	0.082	Tension Compression	— —	— —	— —	4,786 6,208@≤23.5"
1.500-16 (Red or 6)	0.063	Tension Compression	— —	— —	— —	4,479 4,480@≤43.5"
1.500-14 (Green or 4)	0.082	Tension Compression	— —	— —	— —	5,830 6,195@≤39.5"
1.500-13 (Yellow or 3)	0.094	Tension Compression	— —	— —	— —	6,683 7,742@≤34.4"
2 Angles 1.125"x1.125"	0.100	Tension Compression	— —	— —	— —	5,856 2,826@≤20.0"

For SI: 1 in = 25.4 mm, 1 lbf = 4.448 N.

¹The allowable loads are axial loads only.

²For compression members with pin-to-pin lengths greater than shown, the allowable axial load must be reduced for slenderness effects (KL/r) by calculation in accordance with Section E of the AISI S100-16 [Section C4 of the AISI S100-12], using a specified minimum yield strength, F_y , of 46 ksi.

TABLE 6—ALLOWABLE REACTIONS (lbf)^{1,2,3,4,5}

For Top Chord Bearings

Version 1 Truss 2x4	Dist. b (In.)	SS DF-L or MSR 2100f-1.8E			MSR 2400f-2.0E			MSR 2850f-2.3E		
		Dist. a (in.)			Dist. a (in.)			Dist. a (in.)		
		2.50"	3.00"	3.5"+	2.50"	3.00"	3.5"+	2.50"	3.00"	3.5"+
0.50"	2,500	2,700	2,700	2,700	2,700	2,900	3,013	3,082	3,243	
0.75"	2,100	2,100	2,600	2,200	2,500	2,900	2,463	2,708	3,042	
1.00"	1,800	1,800	1,900	2,000	2,000	2,000	2,362	2,362	2,386	
1.25"	1,600	1,700	1,700	1,900	1,900	1,900	2,112	2,112	2,112	

Version 1 Truss 2x6	Dist. b (In.)	MSR 2100f-1.8E			MSR 2400f-2.0E			MSR 2850f-2.3E		
		Dist. a (in.)			Dist. a (in.)			Dist. a (in.)		
		2.50"	3.00"	3.5"+	2.50"	3.00"	3.5"+	2.50"	3.00"	3.5"+
0.50"	2,500	2,700	2,700	3,002	3,212	3,212	3,969	3,969	4,171	
0.75"	2,100	2,100	2,600	2,827	2,827	3,143	3,086	3,186	3,186	
1.00"	1,800	1,800	1,900	2,132	2,393	2,393	2,800	2,948	3,048	
1.25"	1,600	1,700	1,700	1,992	1,992	1,992	2,652	2,758	2,758	

Version 2 Truss 3x4	Dist. b (In.)	LAM-CHORD		
		Dist. a (in.)		
		3.50"	4.25"	5.0"+
0.75"	3,180	3,615	4,280	
1.00"	3,070	3,215	3,810	
1.25"	2,670	3,050	3,215	
1.50"	2,450	2,655	2,900	

For Bottom Chord Bearings

If bearing pin is off support wood (has eccentricity), use values for Top Chord Bearing above.

If bearing pin is on support wood (no eccentricity), use values from Footnote 3 below.

For SI: 1 in = 25.4 mm, 1 lbf = 4.448 N

¹Distance a: The distance from the centerline of the pin in the bearing assembly to the end of the chord.

²Distance b: The distance from the centerline of the pin in the bearing assembly to the nearest edge of the bearing surface.

³The reaction, R, resulting from applied loads, must not exceed the values from above table; the bearing capacities of the supporting wood member, R_s, and chord material, R_c, are determined, respectively, by using the following equations:

$$R_s = F_{c-perp} \times A_{bearing} \times C_b \text{ (lbf)}$$

$$R_c = F_{c-perp} \times A_{bearing} \text{ (lbf)}$$

Where:

B = Bearing length (in) = Distance from inside face of bearing support to end of chord.

W = Width of chord (in) = 3 ½ inches for 2x4 and 3x4 chord or 5 ½ inches for 2x6 chord.

F_{c-perp} = Reference compressive design value perpendicular to grain in NDS for either supporting wood species or chord material species (psi). F_{c-perp} must not be increased by a duration of load factor, C_D.

$$A_{bearing} = \text{Bearing area (in}^2\text{)} = B \times W.$$

C_b = Bearing area factor in accordance with Section 3.10.4 of NDS.

⁴R_s is not applicable when the supporting member is not a wood member.

⁵The maximum allowable reactions tabulated may not be increased for duration of loading (C_D).

NOTE:

A red line is applied to the bottom face of the chord at the maximum distance the bearing pin can be off the bearing surface ($\frac{1}{2}$ " to $\frac{1}{4}$ " determined by reaction). This red line must not be visible when trusses are installed.

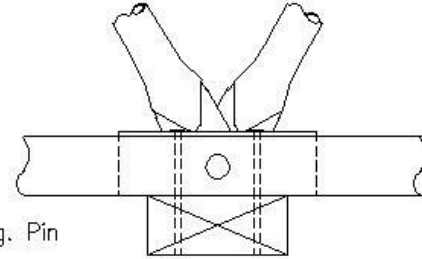
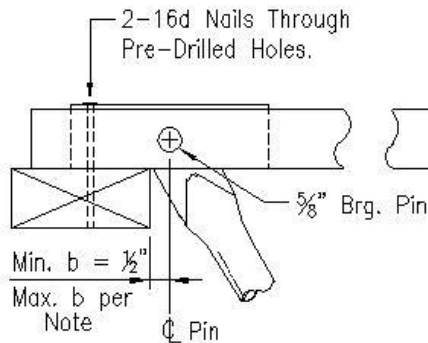
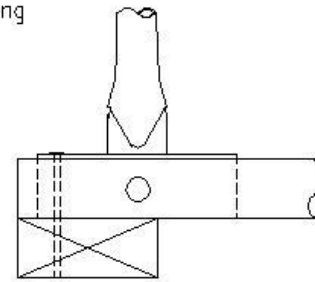
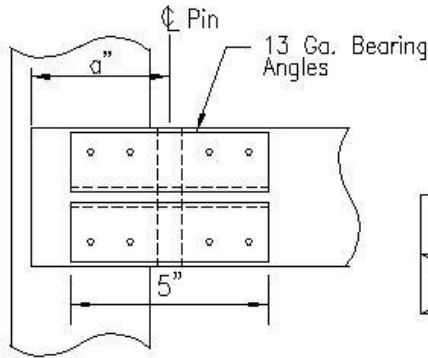
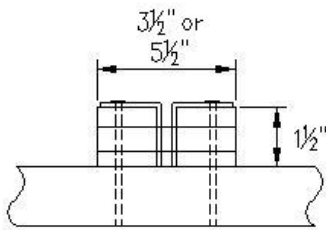

Top Bearing

Bottom Bearing

VERSION 1 TRUSS

NOTE:

A red line is applied to the bottom face of the chord at the maximum distance the bearing pin can be off the bearing surface ($\frac{3}{4}$ " to $\frac{1}{2}$ " determined by reaction). This red line must not be visible when trusses are installed.

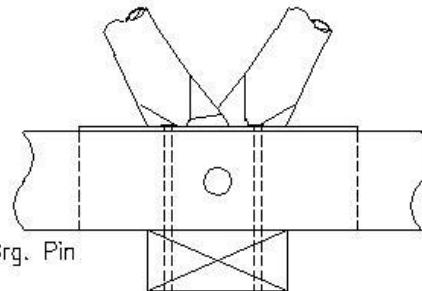
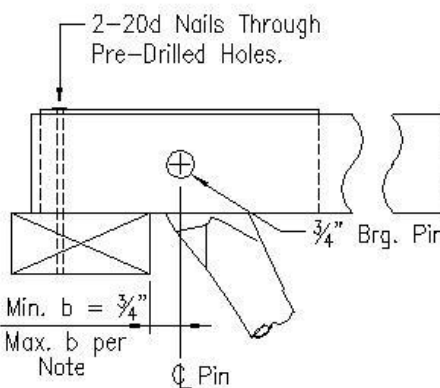
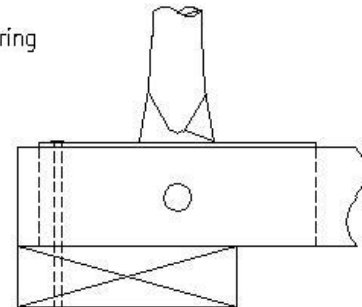
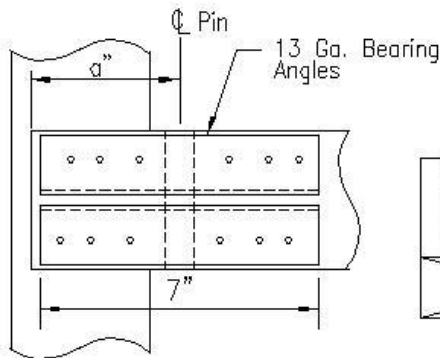
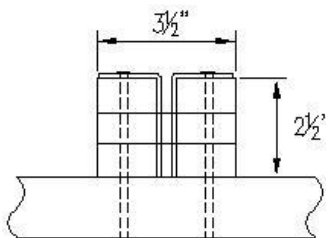

Top Bearing

Bottom Bearing

VERSION 2 TRUSS

For SI: 1 in = 25.4 mm.

FIGURE 2—BEARING DETAILS FOR TRUSSES

DIVISION: 06 00 00—WOOD, PLASTICS AND COMPOSITES
Section: 06 17 00—Shop-Fabricated Structural Wood

REPORT HOLDER:

SWEET'S JOISTS, INC.

EVALUATION SUBJECT:

WEB JOIST™ TRUSSES

1.0 REPORT PURPOSE AND SCOPE**Purpose:**

The purpose of this evaluation report supplement is to indicate that Web Joist™ Trusses, described in ICC-ES evaluation report ESR-2504, have also been evaluated for compliance with the codes noted below.

Applicable code editions:

- 2019 *California Building Code*® (CBC)

For evaluation of applicable chapters adopted by the California Office of Statewide Health Planning and Development (OSHPD) AKA: California Department of Health Care Access and Information (HCAI) and the Division of State Architect (DSA), see Sections 2.1.1 and 2.1.2 below.

- 2019 *California Residential Code*® (CRC)

2.0 CONCLUSIONS**2.1 CBC:**

The Web Joist™ Trusses, described in Sections 2.0 through 7.0 of the evaluation report ESR-2504, comply with CBC Chapter 23, provided the design and installation are in accordance with the 2018 *International Building Code*® (IBC) provisions noted in the evaluation report and the additional requirements of the CBC, as applicable.

2.1.1 OSHPD:

The applicable OSHPD Sections of the CBC are beyond the scope of this supplement.

2.1.2 DSA:

The applicable DSA Sections of the CBC are beyond the scope of this supplement.

2.2 CRC:

The Web Joist™ Trusses, described in Sections 2.0 through 7.0 of the evaluation report ESR-2504, comply with the CRC, provided the design and installation are in accordance with the 2018 *International Residential Code*® (IRC) provisions noted in the evaluation report.

This supplement expires concurrently with the evaluation report, reissued May 2023.