

DIVISION: 06 00 00—WOOD, PLASTICS AND COMPOSITES

Section: 06 17 33—Wood I-joists

REPORT HOLDER:

SWEET'S JOISTS, INC.

ADDITIONAL LISTEE:

WEB JOIST NORTHWEST CORP.

EVALUATION SUBJECT:

WEB-i® WOOD I-JOISTS

1.0 EVALUATION SCOPE

1.1 Compliance with the following codes:

- 2018, 2015 and 2012 *International Building Code*® (IBC)
- 2018, 2015 and 2012 *International Residential Code*® (IRC)

Properties evaluated:

- Structural
- Fire resistance

1.2 Evaluation to the following green code(s) and/or standards:

- 2019 California Green Building Standards Code (CALGreen), Title 24, Part 11
- 2015, 2012 and 2008 ICC 700 *National Green Building Standard*™ (ICC 700-2015, ICC 700-2012 and ICC 700-2008)

Attributes verified:

- See Section 3.1

2.0 USES

The WEB-i wood I-joists described in this report are used as structural framing members in floor and roof assemblies. The structural capacities and design provisions of the WEB-i wood I-joists comply with IBC Section 2303.1.2 for allowable stress design, and IRC Section R502.1.4.

3.0 DESCRIPTION

3.1 General:

The WEB-i joists are prefabricated wood I-joists with lumber flanges and oriented strand board (OSB) webs.

The flanges are solid-sawn lumber with glued finger-joints, which are manufactured and tested daily in accordance with the manufacturer's quality control manual, to form continuous flanges. The face grain of the OSB web is oriented vertically, and the web-to-flange and web-to-web connections are proprietary, glued, tongue-and-groove joints. Joist depths vary from 11⁷/₈ to 28 inches (302 to 711 mm). See Table 1 and Figure 1 for joist descriptions.

The attributes of the wood I-joists have been verified as conforming to the provisions of (i) CALGreen Sections A4.404.3 for efficient framing techniques; (ii) ICC 700-2015 Section 608.1(b), 11.608.1(b) and 12.1(A)608.1(b) (iii) ICC 700-2012 Section 608.1(2), 11.608.1(2) and 12(A).608.1 for resource-efficient materials; and (iv) ICC 700-2008 Section 607.1(2) for resource-efficient materials. Note that decisions on compliance for those areas rest with the user of this report. The user is advised of the project-specific provisions that may be contingent upon meeting specific conditions, and the verification of those conditions is outside the scope of this report. These codes or standards often provide supplemental information as guidance.

3.2 Materials:

3.2.1 Flanges: Flange material is nominally 2-inch-by-4-inch (38 by 89 mm actual) machine-stress-rated (MSR) lumber meeting the grading rules specified in Table No. 4C of the *National Design Specification*® for *Wood Construction* (NDS) *Supplement* and in the manufacturer's quality control manual. Lumber species are Douglas fir–larch, hem-fir, spruce-pine-fir, Engelmann spruce/lodgepole pine or lodgepole pine.

3.2.2 Webs: Webs are 3/₈- or 1/₂-inch-thick (9.5 or 12.7 mm) OSB panels conforming with Structural I, Exposure I, performance-rated panel requirements as noted in U.S. Department of Commerce Product Standard PS-2 and the manufacturer's quality control manual.

3.2.3 Adhesive: The adhesive is an exterior-type adhesive complying with ASTM D2559 and Section 5.3.3 of ASTM D5055-09.

4.0 DESIGN AND INSTALLATION

4.1 Installation:

Installation of the WEB-i wood I-joists described in this report must comply with the applicable code requirements, this report and manufacturer's published installation instructions. The manufacturer's published installation instructions must be available at the jobsite at all times during installation.

4.2 Design:

The WEB-i wood I-joists must be designed using accepted joist design principles and this report.

4.2.1 Design Values: Table 2 specifies reference design moments, shears, and stiffnesses (EI) for the WEB-i wood I-joists installed with simple-spans. Table 3 provides equations that can be used to determine the reference design reactions based on the bearing lengths at the ends of I-joists. Adjustments to the reference design values must be made, as applicable, in accordance with Sections 4.2.5 through 4.2.7. Tapered I-joists are designed in accordance with Footnote 6 of Table 2.

4.2.2 Web Stiffeners: Both sides of the web of joists that are 16 inches (406 mm) and deeper must have web stiffeners installed at all supports. Table 4 specifies web stiffener requirements. At locations where concentrated loads exceed 1,500 pounds (6.67 kN), both sides of the web require stiffeners for all joist depths. See Figure 2.

4.2.3 Lateral Support: The compression flange requires continuous lateral support, and the joist ends require restraint to prevent rollover.

4.2.4 Holes: Figure 3 shows allowable hole size and location of holes in the joist webs. Analysis of the allowable hole size on tapered I-joist must consider the distance from the support and depth of I-joist at the desired hole location.

4.2.5 Duration of Load: Adjustments for duration of load according to Sections 7.3.2 and 12.3.2 of the 2018 and 2015 NDS (Section 11.3.2 of the 2012 NDS for the 2012 IBC and 2012 IRC) apply to the WEB-i wood I-joists and their fastenings, respectively.

4.2.6 In-service Moisture Conditions: The WEB-i wood I-joists must be installed in dry, covered conditions, where the in-service moisture content is less than 16 percent.

4.2.7 Repetitive-member Use: The repetitive member factor for WEB-i wood I-joists shall be taken as 1.0.

4.2.8 Beam Span: Beam span must comply with the code. Vertical shear calculations must include all loads within the span from centerline to centerline of bearing supports.

4.2.9 Deflection: Deflection of uniformly loaded, simple-span joists and joists with a concentrated load at mid-span are determined with the deflection formulae in Footnote 1 of Table 2.

4.2.10 Blocking Panels: WEB-i wood I-joists under bearing walls that are perpendicular to the joists must have full-depth solid blocking.

4.3 One-hour Fire-resistance-rated Roof and Floor-ceiling Assemblies:

WEB-i I-joists used in one-hour fire-resistance-rated roof and floor-ceiling assemblies must be installed in accordance with Section 4.2.2.4 of [ESR-1338](#), or IBC Table 721.1(3) Item Nos. 21-1.1, and 23-1.1 through 28-1.1.

5.0 CONDITIONS OF USE

The WEB-i wood I-joists described in this report comply with, or are suitable alternatives to what is specified in, those codes listed in Section 1.0 of this report, subject to the following conditions:

- 5.1 Installation complies with this report, the manufacturer's published installation instructions and the applicable code. In the event of conflicts between the manufacturer's published installation instructions and this report, this report governs.
- 5.2 Structural design information for the use of the joists must be indicated on the construction documents submitted with the permit application. The construction documents and the design configurations must be consistent with this report, and must be prepared by a registered design professional where required by the statutes of the jurisdiction in which the project is to be constructed.
- 5.3 Cutting of the flanges of the joists is not permitted. Web openings in wood I-joists must conform to the requirements as specified in Section 4.2.4 of this report. Web opening conditions not covered in Section 4.2.4 of this report are outside the scope of this report.
- 5.4 Evaluation of the joists is limited to interior dry-use conditions. Dry conditions of use are those conditions of use represented by moisture content that is less than 16 percent in the wood I-joists.
- 5.5 The joists are manufactured by Web Joist Northwest Corp. in Chehalis, Washington, under a quality-control program with inspections by ICC-ES and PFS Corporation (AA-652).

6.0 EVIDENCE SUBMITTED

Data in accordance with the ICC-ES Acceptance Criteria for Prefabricated Wood I-joists (AC14), dated October 2016.

7.0 IDENTIFICATION

- 7.1 Each WEB-I wood I-joist bears a stamped identification label with the product name (WEB-i Joist), manufacturer's name (Web Joist Northwest Corp.), manufacturer's city and state (Chehalis, WA), evaluation report number (ESR-2974), and the name or logo of the inspection agency (ICC-ES and PFS Corporation). In addition, the flanges of the I-joists are labeled with the applicable lumber grade stamp.
- 7.2 The report holder's contact information is the following:

SWEET'S JOISTS, INC.
118 BOROVEC ROAD
CHEHALIS, WASHINGTON 98532-8714
(360) 748-9376
www.webjoist.com
Bruce@Webjoist.com

- 7.3 The additional listee's contact information is the following:

WEB JOIST NORTHWEST CORP.
118 BOROVEC ROAD
CHEHALIS, WASHINGTON 98532
(360) 748-1173

TABLE 1—WEB-i JOIST DESCRIPTION^{1,2}

SERIES CODE NUMBER	FLANGE GRADE	WEB THICKNESS (inches)	DEPTH RANGE (inches)	SHAPE ³
4212	MSR 1650f-1.5E	3/8	11 ⁷ / ₈ -24	Parallel and Tapered
4312	MSR 1800f-1.6E	3/8	11 ⁷ / ₈ -24	
4412	MSR 2100f-1.8E	3/8	11 ⁷ / ₈ -24	
4512	MSR 2400f-2.0E	3/8	11 ⁷ / ₈ -24	
4612	MSR 2700f-2.2E	3/8	11 ⁷ / ₈ -24	
4712	MSR 2850f-2.3E	3/8	11 ⁷ / ₈ -24	
4232	MSR 1650f-1.5E	1/2	16-28	Parallel
4332	MSR 1800f-1.6E	1/2	16-28	
4432	MSR 2100f-1.8E	1/2	16-28	
4532	MSR 2400f-2.0E	1/2	16-28	
4632	MSR 2700f-2.2E	1/2	16-28	
4732	MSR 2850f-2.3E	1/2	16-28	

For SI: 1 in. = 25.4 mm

¹Series code number: 1st digit – Flange size (nominal 2 inches by 4 inches), 2nd digit = Flange grade, 3rd digit = Web thickness, and 4th digit = Web material (Structural I OSB).

²Flanges are labeled with the applicable grade stamp.

³I-joists are made either with parallel flanges or tapered flanges with a minimum of 0.25 inch per foot tapering slope.

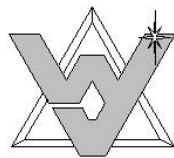

WEB-i[®] All wood I-Joist

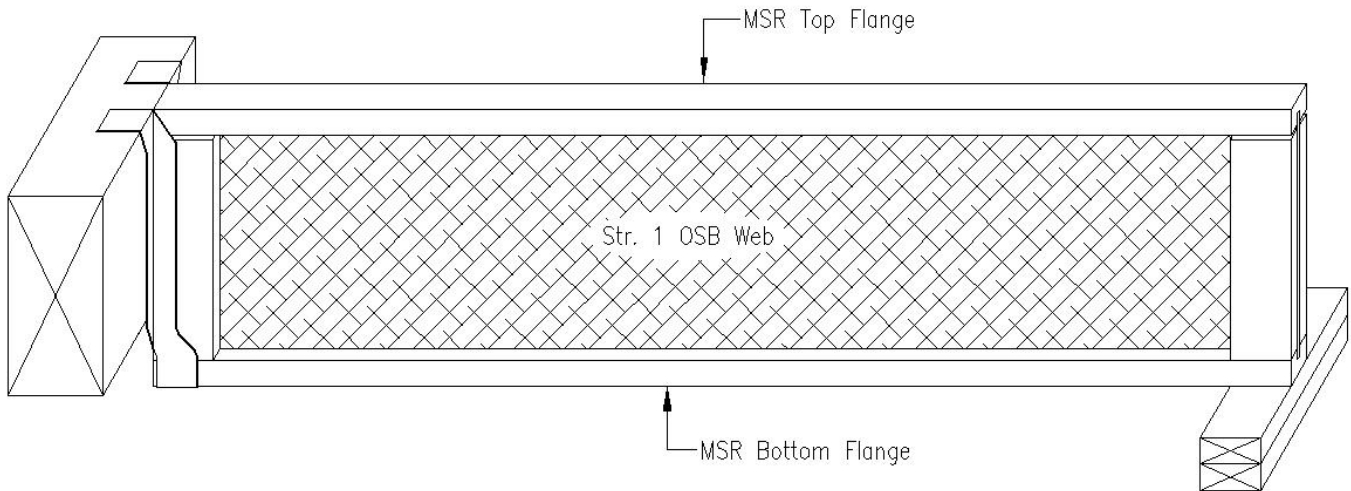

FIGURE 1—WEB-i COMPONENTS

TABLE 2—WEB-I JOIST REFERENCE DESIGN VALUES^{1,2,3,4,5,6}

Depth (in.)	Weight (plf)	Shear V _r (lbf)	Moment M _r (Ft.-lbf)	Elx10 ⁶ EI (lbf-in. ²)	Kx10 ⁶ K (lbf)	Depth (in.)	Weight (plf)	Shear V _r (lbf)	Moment M _r (Ft.-lbf)	Elx10 ⁶ EI (lbf-in. ²)	Kx10 ⁶ K (lbf)
WEB-i 4212 (2x4 1650f-1.5E Flange & 3/8" OSB Web)						WEB-i 4232 (2x4 1650f-1.5E Flange & 1/2" OSB Web)					
11 7/8	3.6	1,929	4,482	443	5.64	16	4.5	2,995	6,168	899	10.13
14	3.8	2,147	5,398	649	6.65	18	4.8	3,187	7,017	1,180	11.40
16	4.0	2,351	6,259	882	7.60	20	5.1	3,379	7,865	1,504	12.67
18	4.2	2,556	7,120	1,154	8.55	22	5.3	3,572	8,713	1,872	13.93
20	4.4	2,760	7,982	1,466	9.50	24	5.6	3,764	9,561	2,286	15.20
22	4.6	2,965	8,843	1,818	10.45	26	5.9	3,957	10,391	2,747	16.47
24	4.8	3,169	9,704	2,213	11.40	28	6.2	4,149	11,139	3,256	17.73
WEB-i 4312 (2x4 1800f-1.6E Flange & 3/8" OSB Web)						WEB-i 4332 (2x4 1800f-1.6E Flange & 1/2" OSB Web)					
11 7/8	3.6	1,929	5,164	473	5.64	16	4.5	2,995	7,106	959	10.13
14	3.8	2,147	6,218	693	6.65	18	4.8	3,187	8,083	1,259	11.40
16	4.0	2,351	7,210	941	7.60	20	5.1	3,379	9,060	1,604	12.67
18	4.2	2,556	8,202	1,231	8.55	22	5.3	3,572	10,037	1,997	13.93
20	4.4	2,760	9,195	1,563	9.50	24	5.6	3,764	11,014	2,438	15.20
22	4.6	2,965	10,187	1,940	10.45	26	5.9	3,957	11,970	2,930	16.47
24	4.8	3,169	11,179	2,361	11.40	28	6.2	4,149	12,831	3,473	17.73
WEB-i 4412 (2x4 2100f-1.8E Flange & 3/8" OSB Web)						WEB-i 4432 (2x4 2100f-1.8E Flange & 1/2" OSB Web)					
11 7/8	3.6	1,929	6,921	532	5.64	16	4.5	2,995	9,525	1,079	10.13
14	3.8	2,147	8,335	779	6.65	18	4.8	3,187	10,834	1,416	11.40
16	4.0	2,351	9,665	1,059	7.60	20	5.1	3,379	12,144	1,805	12.67
18	4.2	2,556	10,995	1,385	8.55	22	5.3	3,572	13,453	2,246	13.93
20	4.4	2,760	12,325	1,759	9.50	24	5.6	3,764	14,763	2,743	15.20
22	4.6	2,965	13,655	2,182	10.45	26	5.9	3,957	16,045	3,296	16.47
24	4.8	3,169	14,985	2,656	11.40	28	6.2	4,149	17,199	3,908	17.73
WEB-i 4512 (2x4 2400f-2.0E Flange & 3/8" OSB Web)						WEB-i 4532 (2x4 2400f-2.0E Flange & 1/2" OSB Web)					
11 7/8	3.6	1,929	8,459	591	5.64	16	4.5	2,995	11,641	1,199	10.13
14	3.8	2,147	10,187	866	6.65	18	4.8	3,187	13,242	1,574	11.40
16	4.0	2,351	11,812	1,176	7.60	20	5.1	3,379	14,843	2,005	12.67
18	4.2	2,556	13,438	1,539	8.55	22	5.3	3,572	16,443	2,496	13.93
20	4.4	2,760	15,063	1,954	9.50	24	5.6	3,764	18,044	3,048	15.20
22	4.6	2,965	16,689	2,425	10.45	26	5.9	3,957	19,611	3,662	16.47
24	4.8	3,169	18,315	2,951	11.40	28	6.2	4,149	21,021	4,342	17.73
WEB-i 4612 (2x4 2700f-2.2E Flange & 3/8" OSB Web)						WEB-i 4632 (2x4 2700f-2.2E Flange & 1/2" OSB Web)					
11 7/8	3.6	1,929	9,448	650	5.64	16	4.5	2,995	13,002	1,319	10.13
14	3.8	2,147	11,377	952	6.65	18	4.8	3,187	14,790	1,731	11.40
16	4.0	2,351	13,193	1,294	7.60	20	5.1	3,379	16,577	2,206	12.67
18	4.2	2,556	15,008	1,693	8.55	22	5.3	3,572	18,365	2,746	13.93
20	4.4	2,760	16,824	2,150	9.50	24	5.6	3,764	20,153	3,352	15.20
22	4.6	2,965	18,640	2,667	10.45	26	5.9	3,957	21,903	4,028	16.47
24	4.8	3,169	20,455	3,246	11.40	28	6.2	4,149	23,478	4,776	17.73
WEB-i 4712 (2x4 2850f-2.3E Flange & 3/8" OSB Web)						WEB-i 4732 (2x4 2850f-2.3E Flange & 1/2" OSB Web)					
11 7/8	3.6	1,929	10,107	680	5.64	16	4.5	2,995	13,909	1,379	10.13
14	3.8	2,147	12,171	996	6.65	18	4.8	3,187	15,822	1,810	11.40
16	4.0	2,351	14,113	1,353	7.60	20	5.1	3,379	17,734	2,306	12.67
18	4.2	2,556	16,056	1,770	8.55	22	5.3	3,572	19,646	2,870	13.93
20	4.4	2,760	17,998	2,247	9.50	24	5.6	3,764	21,559	3,505	15.20
22	4.6	2,965	19,940	2,788	10.45	26	5.9	3,957	23,431	4,212	16.47
24	4.8	3,169	21,882	3,394	11.40	28	6.2	4,149	25,116	4,993	17.73

For SI: 1 in = 25.4 mm, 1 lbf = 4.448 N, 1 pli = 0.124 kg/m, 1 plf = 1.488 kg/m, 1 Ft-lbf = 1.3558 N-m, 1 lbf-in² = 292.64 kg-mm².

¹Calculate bending and shear deflection as follows:

Uniformly distributed load: Defl.(in.) = (5WL⁴ / 384EI) + (WL² / K)

Concentrated load at centerline: Defl.(in.) = (PL³ / 48EI) + (2PL/K)

Where: W = Uniform load (pli)

L = Span length (in.).

EI = Reference design stiffness values of I-joists from the table (lbf-in.² x 10⁶).

K = Shear defl. constant (lbf x 10⁶).

P = Concentrated load (lbf).

²The reference design shear values are based the bearing length of 4 inches at the ends of I-joists.

³Reference design values are for normal load duration. Adjustments to the reference design values must be made, as applicable, in accordance with Sections 4.2.5 through 4.2.7 of this evaluation report.

⁴See Table 4 for web stiffener requirements.

⁵For parallel I-joists, straight line interpolation of the tabulated reference design values may be made between the two adjacent i-joist depths.

⁶For tapered I-joists, straight line interpolation of the tabulated reference shear and moment design values may be made between the depths at the ends of the I-joists. The stiffness, EI, of the tapered I-joist must be determined at the critical moment location using the cross-sectional parameters of the tapered I-joist at the same location.

TABLE 3—REFERENCE DESIGN REACTION FOR BEARING LENGTH^{1,2,3}

For 3/8" Web no Web Stiffeners	$R_r = 723.4 + 45.876D\sqrt{B}$
For 3/8" Web with Web Stiffeners	$R_r = 1353.8 + 39.672D\sqrt{B}$
For 1/2" Web with Web Stiffeners	$R_r = 1741.8 + 42.812D\sqrt{B}$

For SI: 1 in = 25.4 mm, 1 lbf = 4.448 N.

Where:

- R_r = Reference design reaction (lbf).
- D = Out-to-out depth of joist (in.).
- B = Bearing length (in.) and is not to be less than 1.50 inches.

¹The reference design reaction for bearing length is for normal duration of loading and may be increased for duration of loading in accordance with Section 7.3.2 of NDS. The reference design reactions at the bearing length of 4 inches must not exceed the reference design shear values in Table 2.

²The reaction, R, resulting from applied loads, must not exceed the calculated R_r, using the equations in Table 3, the bearing capacities of the supporting wood member, R_s, and flange material, R_f, determined, respectively, by using following equations:

$$R_s = F_{c-perp} \times A_{bearing} \times C_b \text{ (lbf)}$$

$$R_f = F_{c-perp} \times A_{bearing} \text{ (lbf)}$$

where: F_{c-perp}: Reference compressive design values perpendicular to grain in NDS for either supporting wood species or flange material species, psi. F_{c-perp} must not be increased by a duration of load factor, C_D.

A_{bearing}: Bearing area, in²

C_b: Bearing area factor in accordance with Section 3.10.4 of NDS.

³R_s is not applicable when supporting members are not wood members.

TABLE 4—WEB STIFFENERS NAILING^{1,2,3}

Joist Depth (inches)	Total nails per stiffener location			
	Simple Span		Continuous Span	
	3/8" Web	1/2" Web	3/8" Web	1/2" Web
11 7/8	(Box) 3-10d*	(Com.) —	(Box) 4-10d	(Com.) —
14	4-10d*	—	6-10d	—
16	4-10d	4-10d	6-10d	6-10d
18	5-10d	5-10d	7-10d	7-10d
20	6-10d	6-10d	9-10d	9-10d
22	6-10d	6-10d	9-10d	9-10d
24	7-10d	7-10d	10-10d	10-10d
26	—	8-10d	—	12-10d
28	—	8-10d	—	12-10d

For SI: 1 in = 25.4 mm.

¹Web stiffeners are No. 2 or better. Use 2x4's at simple spans and 2x6's at continuous spans. Install nails from both sides.

²May substitute 14 Ga. staples for 10d Box nail and 13 Ga. staples for 10d Common nail. Staples Min. are 7/16" crown and 3" leg.

³Web stiffeners not required for 11 7/8" & 14" deep 3/8" web simple span ends but may be needed for bearing length requirements.

**U"-type hanger may require web stiffeners to comply with nailing requirements through side plates of hanger.

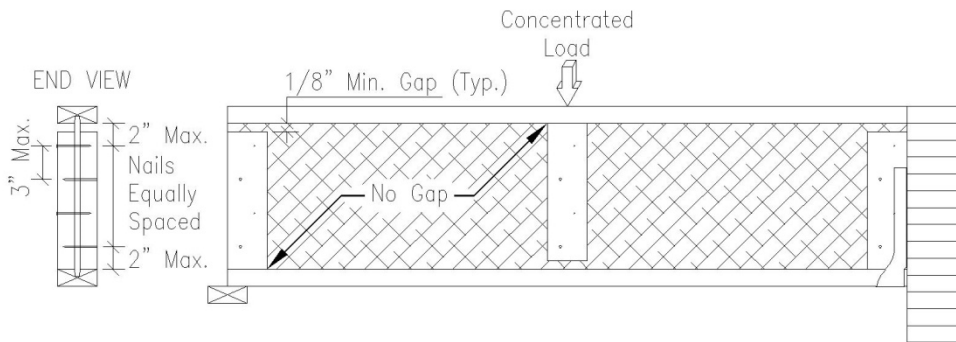
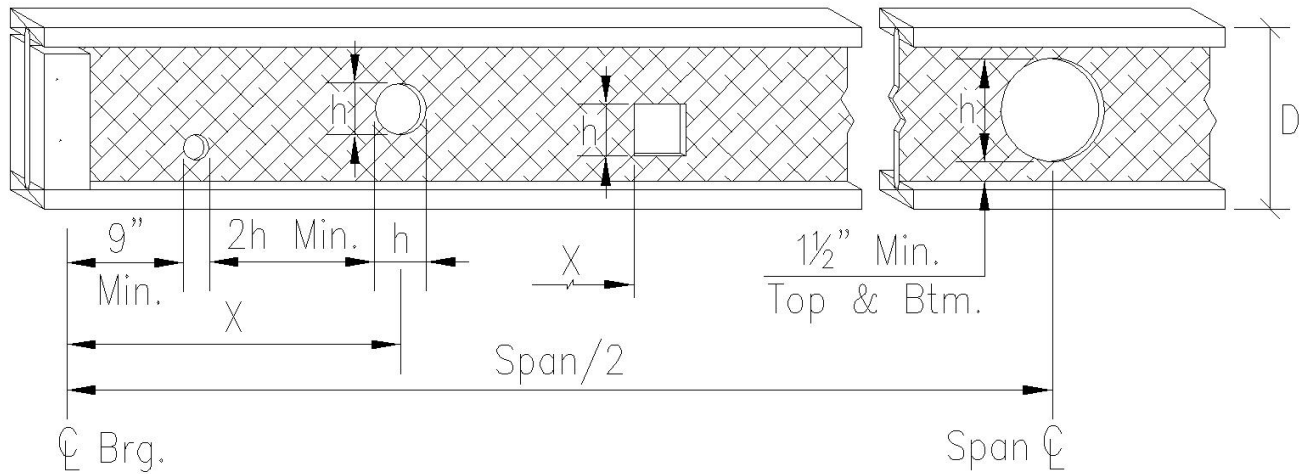

FIGURE 2—WEB STIFFENERS

For SI: 1 in = 25.4 mm.



For simple spans and uniform load, the following formulas may be used to determine minimum distance to hole.

$$X = (V - V_H) / W \quad V = WL/2 \quad V_H = V_A(D_E/D_W)$$

Where:

X = Minimum distance in feet from centerline of support to centerline of round hole or edge of square hole.

V = Shear at bearing in pounds.

W = Uniform loading in pounds per lineal foot.

L = Span in feet from centerline of support to centerline of support.

V_H = Allowable shear at hole in pounds.

V_A = Allowable shear in pounds from Table 8.

D_E = Effective depth at hole in inches (D_E cannot be < 0.5").

@ Round hole D_E = D_W - h

@ Square hole D_E = D_W - (h/0.75)

@ Rectangular hole D_E = D_W - (h/0.6667)

D_W = Depth of web in inches = D - 1.75".

h = Height of hole in inches (h_{max.} to be the lower of D-6" or a value that results in D_E being ≥ 0.5").

D = Out-to-out depth of joist in inches.

NOTES:

1. Do not cut the web within nine inches of the support centerline, otherwise, a two inch hole can be cut in the web anywhere. The top and bottom flanges are never to be cut.
2. Where more than one hole is desired, the length of the web between edges of holes must be equal or exceed twice the height of the largest hole.

FIGURE 3—HOLE SIZE AND LOCATION

For SI: 1 in = 25.4 mm, 1 lbf = 4.448 N, 1 lbf/ft = 1.488 kg/m.

DIVISION: 06 00 00—WOOD, PLASTICS AND COMPOSITES
Section: 06 17 33— Wood I-joists

REPORT HOLDER:

SWEET'S JOISTS, INC.

EVALUATION SUBJECT:

WEB-I® WOOD I-JOISTS

1.0 REPORT PURPOSE AND SCOPE**Purpose:**

The purpose of this evaluation report supplement is to indicate that the WEB-I Wood I-Joists, described in ICC-ES evaluation report ESR-2974, have also been evaluated for compliance with the code(s) noted below.

Applicable code edition(s):

- 2019 *California Building Code* (CBC)

For evaluation of applicable chapters adopted by the California Office of Statewide Health Planning and Development (OSHPD) and Division of State Architect (DSA), see Sections 2.1.1 and 2.1.2 below.

- 2019 *California Residential Code* (CRC)

2.0 CONCLUSIONS**2.1 CBC:**

The WEB-i Wood I-Joists, described in Sections 2.0 through 7.0 of the evaluation report ESR-2974, comply with CBC Chapter 23, provided the design and installation are in accordance with the 2018 *International Building Code*® (IBC) provisions noted in the evaluation report ESR-2974, and the additional requirements of CBC Chapters 16 and 17, as applicable.

2.1.1 OSHPD:

The applicable OSHPD Sections of the CBC are beyond the scope of this supplement.

2.1.2 DSA:

The applicable DSA Sections of the CBC are beyond the scope of this supplement.

2.1 CRC:

The WEB-i Wood I-Joists, described in Sections 2.0 through 7.0 of the evaluation report ESR-2974, comply with CRC Chapters 5, 6, and 8, provided the design and installation are in accordance with the 2018 *International Residential Code*® (IRC) provisions noted in the evaluation report ESR-2974.

This supplement expires concurrently with the evaluation report, reissued July 2020.